

Cylinder Wrench

#250 - T-Handle :



Description :

Steel T-Handle wrench for fuel gas cylinders. Use on Propane or acetylene gas cylinder with 9/32" valve stems.

- 9/32" T-Handle.
- 6" Length, Opening = 0.29".
- Black baked-powder-coated.

#1013 - 10 Way :

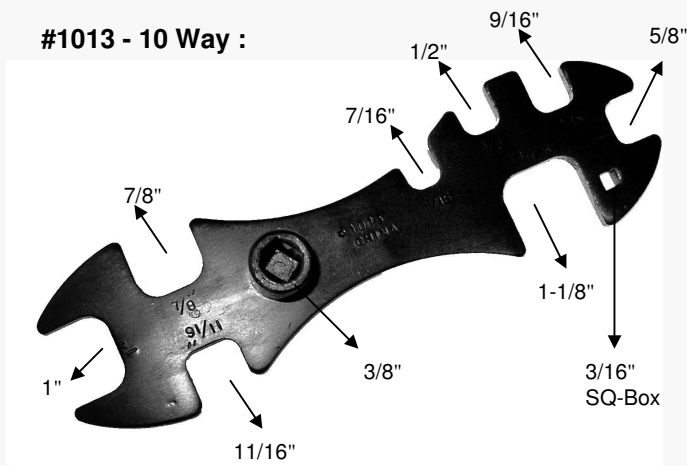

Description :

Heavy duty steel 10 way wrench. Features 10 sizes designed to perfectly fit hose collars, repair parts, tip nuts, gas & oxygen fittings, regulator fittings, and many others.

- Openings : 7/16", 1/2", 9/16", 5/8", 11/16", 7/8", 1", 1-1/8", 3/16" SQ-Box & 3/8" Socket.
- 9" Length.
- Black baked-powder-coated.

#5 - B & MC Box :

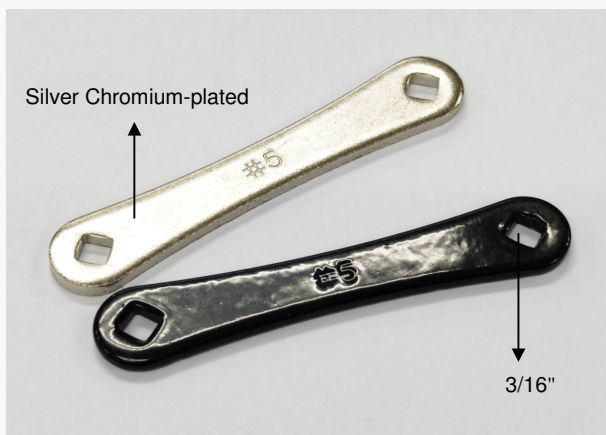

Description :

Sturdy steel wrench for a variety of cylinder regulator torch and tip nut combinations. Use with B and MC cylinders.

- 3/16" B and MC.
- 3-1/8" Length.
- Silver Chromium-plated or Black baked-powder-coated.

GRACEDUTY COMPANY LIMITED

Room 1102 - 1104, 11/F., CRE Centre,
889 Cheung Sha Wan Road, Kowloon, Hong Kong, China
Tel: (852) 2420-5808 (6 Lines) Fax: (852) 2420-5507
E-mail : welding@graceduty.com.hk http://www.graceduty.com.hk

rev.021021